

<https://doi.org/10.32056/KOMAG2021.3.3>

The concept of a screw conveyor for the vertical transport of bulk materials

Received: 10.03.2021

Accepted: 20.07.2021

Published online: 30.09.2021

Author's affiliations and addresses:

¹ KOMAG Institute of Mining Technology, Pszczyńska 37, 44-100 Gliwice, Poland

² Department of Mining and Nuclear Engineering, Missouri University of Science and Technology, Rolla, MO, 65401, USA

* Correspondence:

e-mail: mbidas@komag.eu

Michał BIDAS^{1*}, Greg GALECKI²

Abstract:

Screw feeders and conveyors are mainly used in the following industries: minerals, agriculture, chemistry, pharmaceutical, pigments, plastics, cement, sand and food processing for transporting and mixing the granular materials.

The article presents a synthetic analysis of the conveyors used in the collection and transport systems of loose materials. It focuses on the solutions based on a screw shaft operating vertically or at an angle. A concept of a screw conveyor intended for vertical transport of loose materials is presented. Due to structure and transport properties, the conveyor can replace the oversized bucket conveyor, currently used in one of the industrial plants. A 3D model was developed, illustrating the manufacturing method and introducing the principle of the conveyor operation.

Keywords: power industry, vertical transport, screw conveyor



1. Introduction

Conveyor transport is used in the state-of-the-art production systems to move materials and raw materials over various distances with output of several thousand tons per hour. Conveyor transport units operating in this system may consist of belt conveyors, bucket and screw conveyors, ensuring the transport of material from storage sites to the processing plants [1].

Concept of a screw conveyor for vertical transport of loose material, based on the solutions of conveyor systems used in technological lines of industrial plants [2], as well as innovative solutions cited in the literature [3] are presented. The vertical working position means that the carried material is more compressed during lifting and occupies a larger part of the trough than in the horizontal solution [4,5]. The screw conveyor - which in this case plays the role of a lift - is to replace in the target project, the bucket conveyor currently used in one of the plants. This conveyor is positioned at an angle and due to its dimensions as it collides with state-of-the-art weighing devices installed for modernization of a part of the production unit. The screw conveyor of the lifting height 6.8 m, will be used to transport the raw material from the grate conveyor, operating on the lower level of the production hall, to the crusher installed on its higher level. Then the raw material will be directed for further processing.

2. Materials and Methods

Screw conveyors are used in the lime, cement, power, agricultural and food industries. As noted by the authors of articles about screw conveyors, the transport of loose materials is a complex process and depends not only on the parameters of the screw shaft or its enclosure, but also on the physical properties of the transported material. Traditional computational methods allow for the selection of each of the conveyor parameter with great precision for materials such as lime or cement, but when the transported material has a tendency to crumble or is highly abrasive, then there may be problems related to achieving the assumed efficiency [6]. The analysis of the screw conveyor efficiency depending on the type of loose material was described in [7].

Generally, conveyors can be divided into inclined (Fig. 1) and vertical (Fig. 2) ones.

Screw conveyors are used as devices collecting material from various types of tanks and silos. They are also used to dose the product in technological processes. Due to the closed structure, the transported material can be isolated from the environment.



Fig. 1. Inclined screw conveyor [9]



Fig. 2. Vertical screw conveyor with a feeder [10]

Screw conveyors are divided into two types: with closed trough and open trough. The former usually have a trough in the shape of a tube or "U" shape with lids, while the latter have a "U" shape (without lids).

The screw conveyor consists of a trough inside which there is a shaft with a wound screw ribbon. The rotating shaft moves the transported material. The solution of screw conveyor is based on the so-called Archimedes screw.

The feeder is driven by the screw shaft or directly by the screw (in the case of shaftless screws) [8].

3. Results – concept of a new solution

The screw conveyor presented in this publication, serves as a vertical feeder in an industrial plant. The conceptual drawing of the conveyor is shown in Fig. 3, while its spatial model with its main components is shown in Fig. 4.

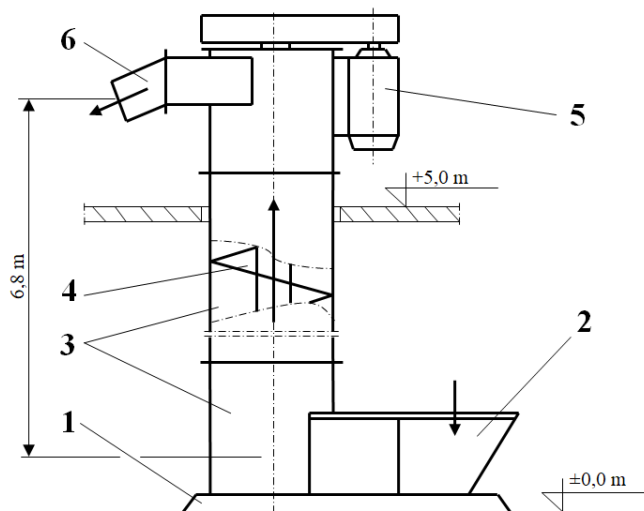

Fig. 3. Conceptual drawing of the screw conveyor: 1 – base, 2 – feeding chamber, 3 – trough segments, 4 – screw shaft, 5 – drive unit, 6 – outlet stub

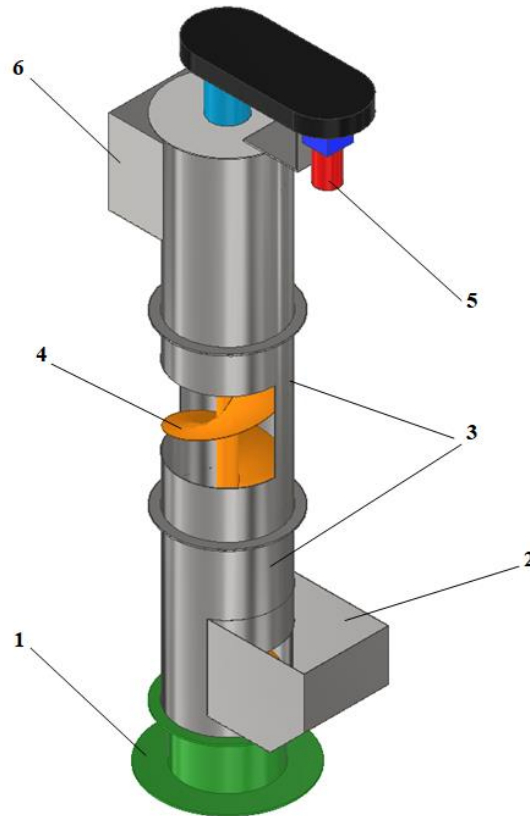

Fig. 4. The spatial model of the conveyor: 1 – base, 2 – feeding chamber, 3 – trough segments, 4 – screw shaft, 5 – driving unit, 6 – outlet stub

Development of the device concept and then the spatial model required adopting a number of assumptions regarding its technical parameters, assembly method and working conditions, such as the following:

- | | | |
|---|---|--------------|
| – conveyor output | Q | 20 t/h |
| – height of material lifting | H | 6,8 m |
| – suggested range of the screw diameter | D | 400 ÷ 600 mm |
| – screw pitch equal to its diameter | S | S = D |
| – screw troughs | | closed |
| – working position of the screw conveyor | | vertical |
| – assembly and installation of the screw conveyor in accordance with the requirements of relevant standards and directives, | | |
| – operation of the device in a ventilated closed room, | | |
| – drive transmission from the motor to the screw shaft using a belt transmission. | | |

The base of the conveyor (Fig. 4, Item 1) is made of two metal sheets and a steel block. The upper sheet is made of 0H18N9 stainless steel. The holes made in it will be used in detachable connection of the base with the trough segment. The steel block (rectangular or cylindrical) contains a bearing seat for the screw shaft and a lubricating channel.

The charging chamber (Fig. 4, item 2) is a tank made as a welded structure from 0H18N9 stainless steel, 2 mm thick and with overall dimensions depending on the surrounding conditions. It has been assumed that the upper edge of the chamber will be located above the inlet in the lower segment of the trough. Therefore, the feeding chamber also acts as a buffer for the material transported by the screw conveyor, used in the case of increased feed from the previous conveyor or storage tank.

The trough segments (Fig. 4, item 3) are tubular components made of 0H18N9 stainless steel with welded flanges for screwed connections. Flanges are made of two bent angles welded into a $\phi 664$ mm circle. Tubular components are made of metal sheet. After bending to form a pipe and welding, the sheets are installed inside the flanges. A rubber gasket is expected to be used at the joints between each segment. It has been assumed that all welded and screwed joints should be made as leakproof. Installation of three pipe segments are planned, the lower and upper one have openings at the place of the feeding channel and outlet stub.

The screw shaft (Fig. 4, item 4) is a rod, graded at the top and bottom bearings, and a pulley with indentation for a prismatic key. Screw blades are welded to the shaft, forming a screw outline. It is assumed that the method of joining each blade (e.g. butt or overlapping) will be determined in the final conveyor design. The screw shaft is also expected to be made of 0H18N9 stainless steel.

The drive unit (Fig. 4, Item 5) is a combination of a two-stage gearmotor with an electric motor. On the basis of preliminary calculations, to achieve the expected capacity of 20 t/h, use of the SK62-106M geared motor from NORD Napędy Sp. z o.o., with a power of 9.2 kW and rotational speed of the output shaft, equal to 201 rpm, was assumed. The driving torque will be transmitted to the screw shaft through a belt transmission to achieve the required output of the device. The gear ratio of the belt transmission was assumed to be approximately 1.09. The gearbox will be equipped with C-type V-belts. Parameters such as the length and wrap angle as well as the size of the pulleys will be specified in the final design. The gearmotor selected for use in the screw conveyor is shown in Fig. 5.



Fig. 5. SK62 type gearmotor [11]

The outlet stub (Fig. 4, item 6), similarly to the feeding chamber, is to be made of 2 mm thick metal sheet with dimensions depending on the surrounding conditions. 0H18N9 steel is a material used for manufacture. It is possible to make the stub coaxially with the feeding chamber or according to the turn of the production line, e.g. 45 degrees in the horizontal plane. Location of the outlet stub results from the functional features of the conveyor, which can not only change the capacity, but also the direction of the transport line.

4. Conclusions

Growing demand for various types of conveyors in many industries has resulted in the development of specialization in their production. Conveyors, like other machines and technological devices, should comply with specific requirements and principles of design, assembly and operation.

Screw conveyors are the conveyors used in many industries, including power, food and agriculture industry.

The article presents the concept of a screw conveyor intended for transporting the loose material in an industrial plant. Proper selection of components and the design of the conveyor enable achieving the main requirements regarding the raw material transport with the assumed capacity of 20 t/h. It is an alternative solution to the inclined scraper conveyor and bucket elevating system, currently operating

on the modernized section of the technological line for processing loose material in an industrial plant. Replacing these two devices with one new generation transporter should bring the following benefits:

- additional free space will be created within the production hall, which can be used for the installation of other devices of the technological line,
- use of a vertical conveyor will enable reducing the operating costs and servicing of the modernized section of the technological line,
- the energy efficiency of devices operating in the area of the technological line will be improved,
- the risk related to unplanned production downtime will be limited,
- the drive used in the screw conveyor will allow for smooth adjustment of the speed of material feeding to the upper level of the hall, depending on the capacity required by production needs.

References

- [1] Kusińska E.: Stan obecny i tendencje rozwojowe transportu wewnątrzzakładowego w przemyśle rolnospożywczym. Wydawnictwo Uniwersytetu Przyrodniczego w Lublinie, Lublin, 2009.
- [2] Bieńkowski, M.: Rodzaje przenośników i ich zastosowania. Powd. Bulk. 2017, Issue 7, 18-23.
- [3] Rubacha P: Projektowanie innowacyjnych przenośników ślimakowych. Transport Przemysłowy i Maszyny Robocze, 2021, Tom 1
- [4] Obertyński A: Przenośniki do materiałów sypkich. Państwowe Wydawnictwo Techniczne, Warszawa 1961
- [5] Roberts A.W.: The influence of granular vortex motion on the volumetric performance of enclosed screw conveyors. Powder Technology Volume 104 (1999), Issue 1,
- [6] Karwat B., Rubacha P., Stańczyk E.: Simulational and experimental determination of the exploitation parameters of a screw conveyor. Eksploatacja i Niezawodność – Maintenance and Reliability Volume 22 (2020), Issue 4, DOI: 10.17531/ein.2020.4.18
- [7] Wang Y, Li T, Muzzio F J, Glasser B J.: Predicting feeder performance based on material flow properties. Powder Technology 2017
- [8] Blaschke S.: Przeróbka mechaniczna kopalin. Część II. Wydawnictwo „Śląsk”, Katowice 1984
- [9] <http://polish.wastewatertreatmentmachine.com/sale-11021010-inclined-powder-worm-screw-conveyor-for-auger-conveyor-systems-stainless-steel.html> [accessed: 10.02.2021]
- [10] <https://agromil.pl/przenosnik-pionowy-z-pomocniczym/825-przenosnik-slimakowy-pionowy-z-podajnikiem-pomocniczym.html> [accessed: 10.02.2021]
- [11] https://www.nord.com/media/documents/bw/g1000_pl_1810.pdf [accessed: 10.02.2021]