

Innovative Mining Techniques and Technologies – Review of Selected KOMTECH-IMTech 2019 Conference Proceedings – Part 2

Published online: 06-07-2020

Małgorzata Malec^{1a}, Lilianna Stańczak¹

¹ KOMAG Institute of Mining Technology, Pszczyńska 37, 44-101 Gliwice, Poland

^a e-mail: mmalec@komag.eu

Keywords: mining machines, technical documentation, longwall shearer, road-header, conveyor, winder, powered roof support, separator, jig

Słowa kluczowe: maszyny górnicze, dokumentacja techniczna, kombajn ścianowy, kombajn chodnikowy, przenośnik, maszyna wyciągowa, sekcja obudowy zmechanizowanej, separator, osadzarka

Abstract:

Some papers, presented at the 20th Jubilee Scientific and Technical Conference KOMTECH-IMTech 2019, are discussed in the article. Part 1 of the article, published in the Quarterly “Mining Machines” No. 1, concerned the role of coal in the global economy, the importance of the coal sector for the Polish economy, the security of energy supply as well as technical and technological achievements of the coal sector over the years 2011-2017. Special attention was paid to automation and digitalization in coal mines, health and safety issues, a protection of the environment, sustainable coal technologies and also to an improvement of the coal use. Part 1 was ended with a description of the KOMAG Institute’s contribution to a development of the Polish mining industry in Sovereign Poland. Part 2 of the article concentrates on the role of the KOMAG Institute of Mining Technology in development processes of mining machines and equipment in Sovereign Poland. Over the period of nearly seventy years of the KOMAG scientific and technical activity more than 1100 technical documentations of mining machines and equipment for underground winning and for a beneficiation of coal were developed. The article also contains some information about Mine 4.0 in theory and practice.

Streszczenie:

W artykule omówiono wybrane referaty, zaprezentowane podczas XX Jubileuszowej Konferencji Naukowo-Technicznej KOMTECH-IMTech 2019. Część 1. artykułu, opublikowana w Kwartalniku „Mining Machines” nr 1, dotyczyła roli węgla w światowej gospodarce, znaczenia sektora węglowego dla polskiej gospodarki, bezpieczeństwa energetycznego oraz technicznych i technologicznych osiągnięć sektora węglowego w latach 2011-2017. Szczególną uwagę zwrócono na automatyzację i cyfryzację w kopalniach węgla, kwestie zdrowia i bezpieczeństwa, ochronę środowiska, zrównoważone technologie węglowe, a także doskonalenie sposobów wykorzystania węgla. Część 1. została zakończona opisem wkładu Instytutu KOMAG w rozwój polskiego przemysłu wydobywczego Niepodległej Polski. Część 2. artykułu koncentruje się na roli, jaką Instytut Techniki Górniczej KOMAG odgrywał i odgrywa w procesach rozwoju maszyn i urządzeń górniczych w Niepodległej Polsce. W ciągu prawie siedemdziesięciu lat działalności naukowo-technicznej Instytutu KOMAG opracowano ponad 1100 dokumentacji technicznych maszyn i urządzeń górniczych do podziemnego pozyskiwania i wzbogacania węgla. Artykuł zawiera także informacje na temat Kopalni 4.0 w teorii i praktyce.

1. Role of the KOMAG Institute of Mining Technology in development processes of mining machines and equipment in Sovereign Poland

The KOMAG Institute of Mining Technology dates back to 1950 [5]. Over the period of nearly seventy years it changed its name and organizational scheme, but it was always oriented onto designing, testing and implementing mining machines and equipment for winning and beneficiation of minerals, in particular hard coal. Since 1950 over 1100 technical designs of mining machinery, implemented in mines, have been developed [4]. An innovative character of technical and

technological solutions is confirmed by 4400 patents and utility patents granted to KOMAG over the period of its scientific, research and technical activity [7].

In the fifties the WŁE-30ch heading coal-cutter (Fig. 1), the KW-1 cutter-shearer (Fig. 2) and the first KWB-3 longwall shearers (Fig. 3) started their operation.

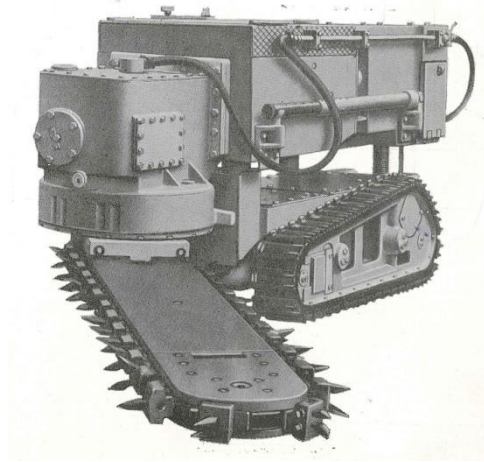

Fig. 1. WŁE-30ch heading coal-cutter [KOMAG]

WŁE-30ch heading coal-cutter (Fig. 1) was designed for cutting horizontal, vertical and askew bottom cuts in coal, coal and stone headings and shortwalls. It could make next-to-the floor cuts in the distance up to 500 mm and from 1200 mm to 1600 mm from the floor. The machine was mounted on a caterpillar chassis which enabled its operation in inclined workings [16].

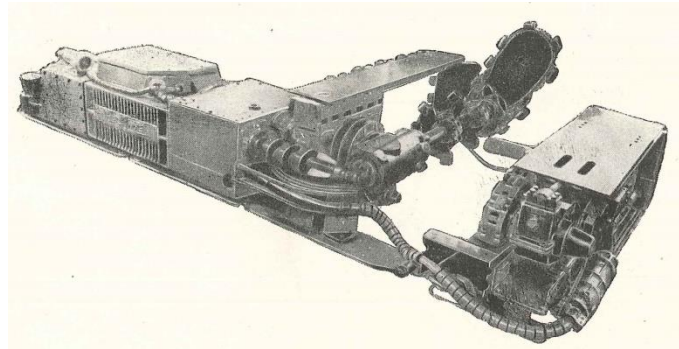

Fig. 2. KW-1 cutter-shearer [16]

KW-1 cutter-shearer (Fig. 2) was used for simultaneous coal cutting and loading to the conveyor in the longwall system. It was operated in the seams of the height from 0.9 to 1.8 m inclined up to 15° for cutting coal of medium hardness [16].

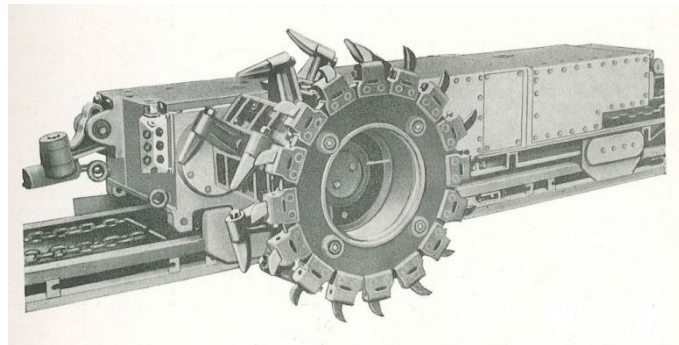

Fig. 3. KWB-3 longwall shearer [KOMAG]

KWB-3 longwall shearer (Fig. 3) was a single drum machine installed on a scraper conveyor of SAMSON type. It operated together with individual steel units or mechanized roof supports of OSM type. It was designed for longwall faces of the height from 1 m to 2 m. It could be used for cutting hard and difficult-to-be mined coal [1].

Apart from technical documentations of cutters and shearers also technical documentations of other machines were developed: ŁZK-5P overhead loaders (Fig. 4), ŁCh-2 shaft loaders (Fig. 5), SKAT scraper conveyor (Fig. 6), Koepe pulley winder of K-2500/Z type (Fig. 7) and double drum hoisting machine of BB-3000/B type (Fig. 8).

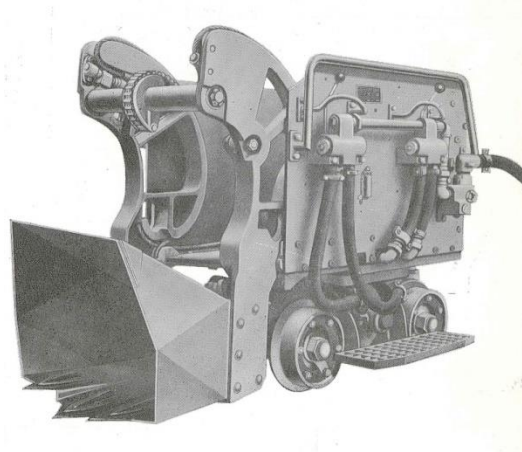

Fig. 4. ŁZK-5P overhead loader [KOMAG]

ŁZK-5P overhead loader (Fig. 4) was used for loading the run-of-mine in horizontal workings such as (headings, cross-cuts) of the height up to 2.2 m. It was equipped with two STG-9 pneumatic engines. It could also operate on the surface for loading stone, ore and debris.

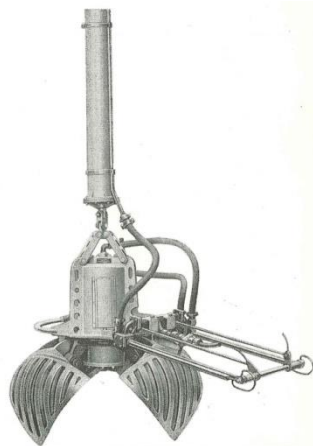

Fig. 5. ŁCh-2 shaft loader [KOMAG]

ŁCh-2 shaft loader (Fig. 5), equipped with pneumatic drive, was used for loading comminuted rock to buckets used at shaft sinking. It was easy to operate due to a simplified air circulation, an improved control of the grab movements and of the hoist as well as a relatively small weight.

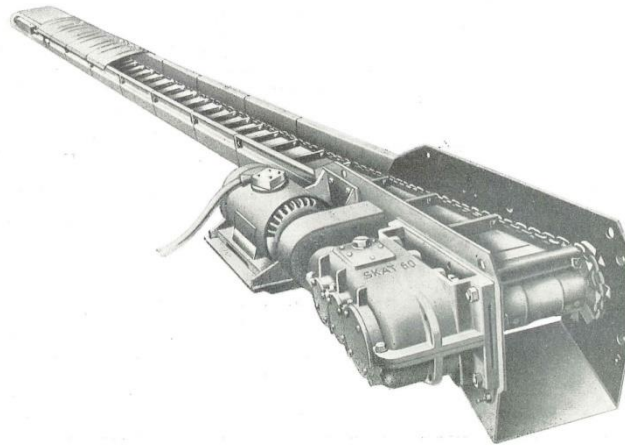

Fig. 6. SKAT-60 scraper conveyor [KOMAG]

SKAT-60 scraper conveyor (Fig. 6) was designed for haulage of the run-of-mine from headings, shortwalls and open-ends as well as from longwall faces inclined up to $\pm 18^{\circ}$. The conveyor was flexible $\pm 3^{\circ}$ in the horizontal plane (between two line pans) which enabled its operation on corrugated floors.

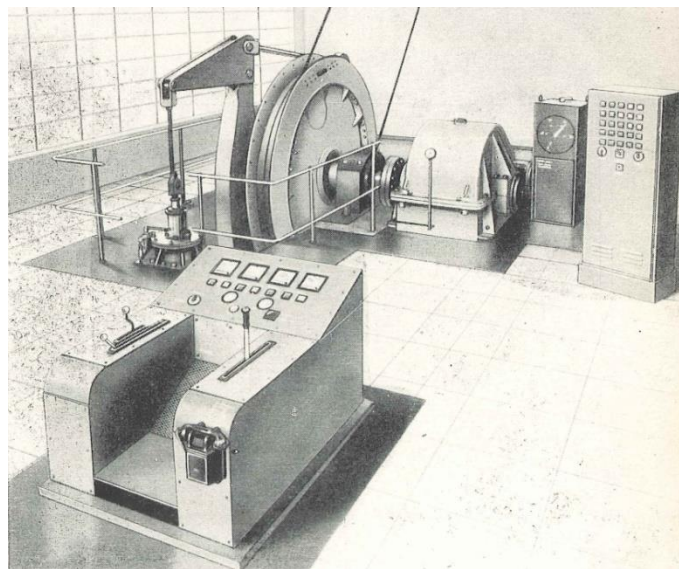

Fig. 7. Koepe pulley winder of K-2500/Z type [KOMAG]

Koepe pulley winder of K-2500/Z type (Fig. 7) was a single rope machine used for double and single cage with a counterweight installation. The machine could be installed over or next to the shaft both on the surface or underground. Control was performed from the control desk. It was equipped with a full protective system required in the case of hoisting men at the speed of 4 m/s. The brakes were controlled electro-pneumatically.

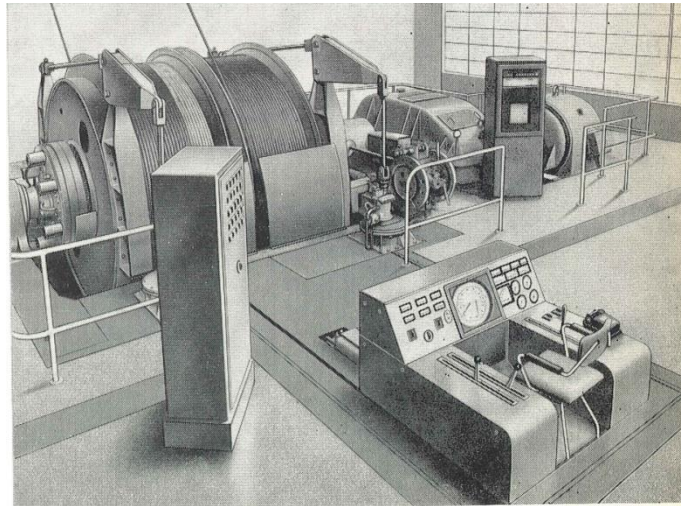

Fig. 8. Double drum winder of BB-3000/B type [KOMAG]

Double drum winder of BB-3000/B type (Fig. 8), equipped with an asynchronous drive, was used for double cage installations in the case of hoisting from different levels and for two-bucket systems used for shaft sinking at the speed of 6 m/s.

The machine was equipped with a reversible system of drums enabling an easy change of spacing between the winding zones of the drums according to spacing of the pulleys.

Powered roof supports of OSM type (Fig. 9) were developed together with specialists from the GIG Central Mining Institute (Katowice, Poland).

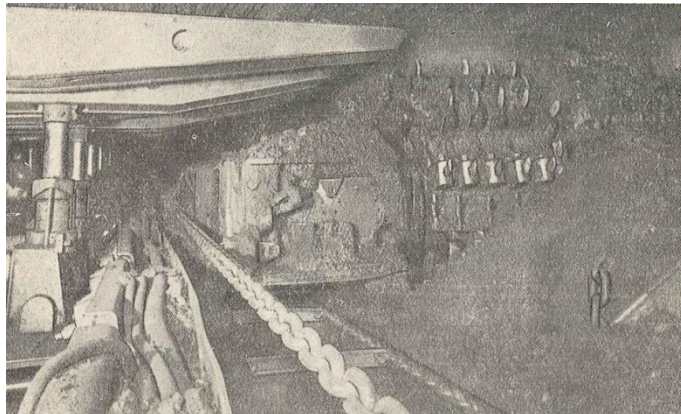

Fig. 9. OSM powered roof support [KOMAG]

In the sixties pillar supports in the frame (Fig. 10) and chock (Fig. 11) versions were designed.

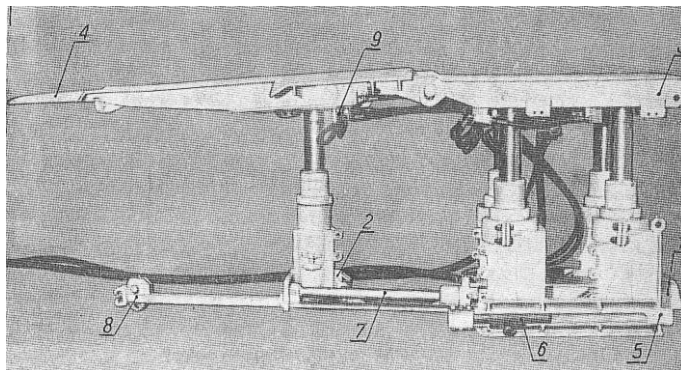

Fig. 10. KRAB-1 frame pillar support [2]

KRAB-1 frame pillar support [2] was designed for use in low seams from 0.8 to 1.3 m (horizontal and inclined up to 35°), mined in the caving system. The numbers in Fig. 10 indicate as follows: 1 – frame base, 2 – separate plate, 3 – articulated frame canopy, 4 – additional canopy extended manually, 5 – conducting rod, 6 – sleeve, 7 – hydraulic advancing ram, 8 – advancing head and control manipulators.

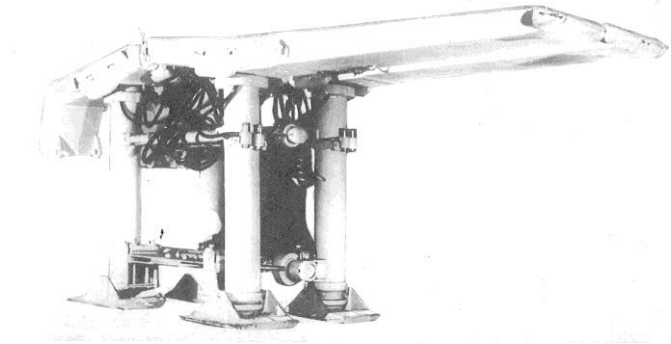

Fig. 11. FAZOS-70 chock pillar support [15]

The FAZOS Factory of Longwall Roof Supports produced the FAZOS-70 chock pillar supports (Fig. 11), designed for operation in medium-thickness seams inclined up to 35° . There were two types of that design: FAZOS-12/23 Pz [15] for seams from 1.2 to 2.3 m thick and FAZOS-18/35 for seams from 1.8 to 3.5 m thick.

In that period of time technical documentations of the first pulsatory jigs, BOB-5500/630 bobin hoisting machine, WW-2Ms drilling jumbo, DEKO 75/100z winch and WL4-2000 four-rope hoisting machines (Fig. 12) were elaborated.

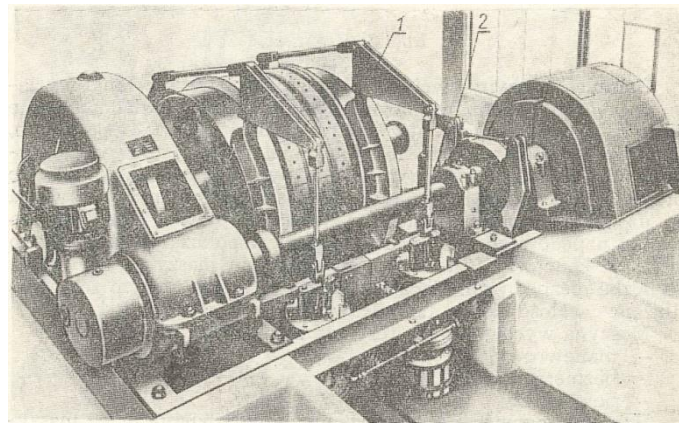

Fig. 12. WL4-2000 four rope hoisting machine [2]

WL4-2000 four rope hoisting machine (Fig. 12) was equipped with manoeuvre brakes (1) and emergency brake (2) which operated using the same shoes. Those brakes had independent drives and the control was carried out with use of relay mechanisms.

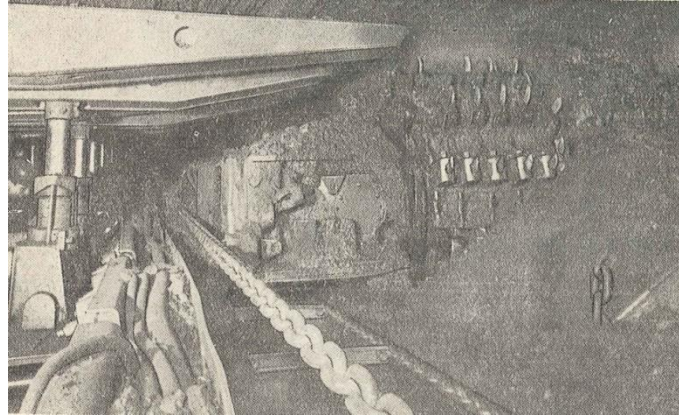

Fig. 13. OSM-1B powered roof support operating together with PZS – Samson conveyor and KWB-3 shearer [2]

The longwall system, shown in Fig. 13, enabled to reduce operational costs significantly due to an increase in production rates. Bumping seams could be mined without any hazard to miners because it was possible to use different control systems, including automatic ones.

In the seventies over 22000 of the FAZOS 12/28 Oz powered roof support units, designed at KOMAG, were produced. Presenting the information about the machines and equipment from that period KWB-6 two ranging arm shearer, SWP coal plough, SUPER SAMSON-NP face conveyor, SOW-80 TP longwall hanging support, equipment for mechanical dust control, AZZ-250A power pack, AW-3 water apparatus, EWA-15 drilling jumbo, AM-50 road-header, Gwarek 1200 and 1400 belt conveyors, KWB 3 RDUW drum shearer, in which the chain was replaced by the Polish chainless haulage system of POLTRAK II type, should be mentioned.

In the eighties research and development projects at KOMAG concentrated on the machines and equipment such as: KGS-160N longwall shearer, GLINIK-055/150zM shield support operating together with SWS-6N plough, RYBNIK 80 scraper conveyor with POLTRAK II haulage system, WPT-3 trapezoid vibratory feeder, KWB 3 RDUW/160 longwall shearer, SKAT/E/180 scraper conveyor, DISA-2 KU-3500P suspension separator, KGS-560 longwall shearer, B-2000 hoisting machine, WOW-1.5 dewatering vibrating centrifuge, PWP 1x3x6 and PWP2 2.4x4.5 vibratory screens, ZPP-ZZ scraper loader, KWM 780E longwall shearer, SKS-60 rail-mounted haulage unit and OG-800Ch roadway dust control installation.

In 1983 590 longwall shearers were in operation in the Polish hard coal mines and 564 of them were produced by the FAMUR Factory of Mining Machines (Fabryka Maszyn Górniczych), basing on the technical documentations developed at the KOMAG Institute [3].

In the nineties technical documentations of the machines, presented below were developed. KSE 344, 500, 700, 800/1000 longwall shearers were applied in longwall faces of high production concentration. KSE-1000, supplied with 6 kV, enabled to achieve daily output reaching 7500 tons. In Fig. 14 and in Fig. 15 KSE-500 and KSE-1000 shearers are shown respectively. KSE-500 was designed for an application in longwall faces of the height between 2.0 and 4.0 m, KSE-1000 – between 1.9 and 4.0 m [8].



Fig. 14. KSE-500 longwall shearer [KOMAG]

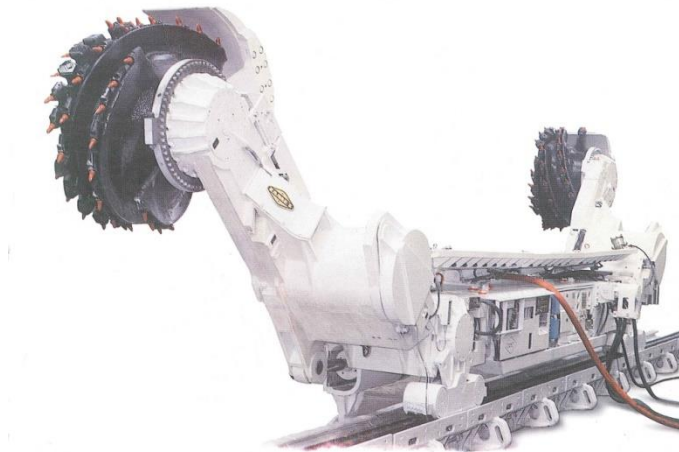

Fig. 15. KSE-1000 longwall shearer [KOMAG]

All the shearers of KSE type were equipped with AC motors controlled by frequency converters, located in road-headings. The control system enabled to automate the haulage speed, adapting the machine to the in-situ mining and geological conditions. This type shearers were equipped with chainless haulage and diagnostic systems enabling a current control of the motors' load as well as of the main assemblies' temperature. The hydraulic systems were used only for raising and lowering ranging arms as well as for releasing the parking brakes. Due to an implementation of narrow ranging arms it was possible to introduce stableless cutting systems. An efficient dust control was achieved due to an implementation of the internal water spraying system installed in the ranging arms [9, 12, 13].

Another interesting design solution, developed in the nineties, was the PSZ-750 scraper conveyor (Fig. 16).

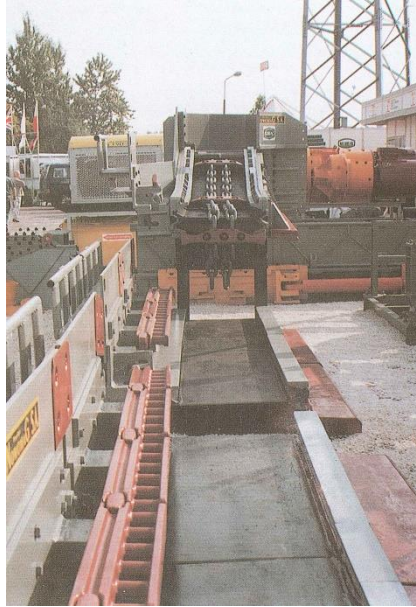

Fig. 16. PSZ-750 scraper conveyor [KOMAG]

PSZ-750 scraper conveyor, shown in Fig. 16, was produced by the NOWOMAG Factory of Mining Equipment. Its capacity reached 750 tons/hour and the power of drives was 200 kW. It was implemented in the following coal-mines: Gliwice, Dębieńsko, Mysłowice, Śląsk, Wesola, Jastrzębie, Niwka-Modrzejów and Borynia.

In the same time intensive development projects were conducted on suspension separators and vibratory screens.

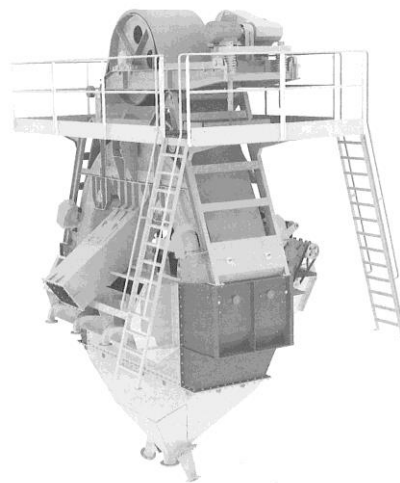

Fig. 17. DISA 2S suspension separator [10, 14]

DISA 2S suspension separator, shown in Fig. 17, was designed for a two-product beneficiation process. The feed was divided into two fractions: the floating one and the sinking one in the dense medium trough. The floating fraction moved along the dense medium current towards the overflow, where it was removed with a scraper. The sinking fraction, after having fallen down to the raising wheel, was directed to the chute.

The SKZ-81 rail-mounted toothed haulage unit (Fig. 18) should be mentioned as well due to its innovative character and many technical advantages.

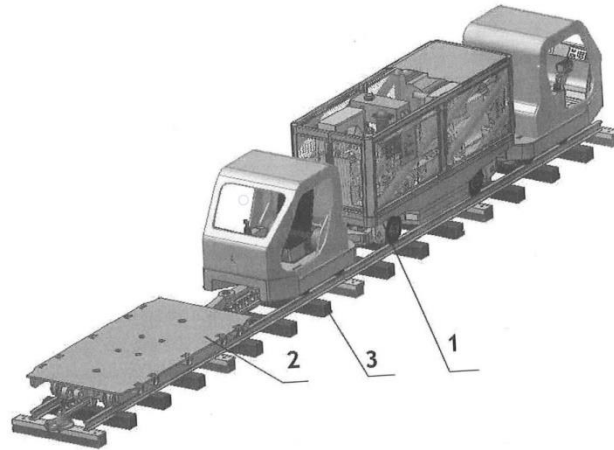

Fig. 18. SKZ-81 rail-mounted toothed haulage unit [KOMAG]

SKZ-81 haulage unit with a double drive system where 1 - haulage unit, 2 – platform, 3 – track was designed for an application in coal, salt or other minerals mines where the “a”, “b” and “c” methane explosion hazards and “A” and “B” classes of dust explosion hazard occur. Due to its construction it is possible to transport heavy assemblies from the shaft to the faces without any need of their unloading and reloading. It is equipped with a Volvo Penta D5AT engine which drives an assembly of hydraulic pumps which supplies hydraulic engines of the wheels or the engine of the toothed bar drive. The engine power is 81 kW and the maximal haulage force reaches 220 kN. It can be used for transporting components of 13500 kg weight.

After the year 2000 research and development projects at the KOMAG Institute of Mining Technology were also oriented on designing, testing and implementing new or modernized jigs, suspension separators, dust control installations and noise control systems. It is worth mentioning an innovative solution of a scraper conveyor with drives’ control system, WIG-200 engineering and geological drill rig, MWM-1 drilling jumbo, PCA-1 battery-driven suspended haulage unit, B-4300/DC hoisting machine, Lda-12K-EMA battery – driven locomotive for underground applications, KSW-750 E and KSW-950 E longwall shearers as successes of the KOMAG researchers and specialists playing an important and significant role in making mining operations safer and more profitable. Technical and scientific achievements in a development of preparation machinery should be highlighted. Over the years 1955-2018 technical documentations of 320 separators, including over 200 jigs, operating in Poland and abroad: in Brazil, China, India, Romania and Vietnam were elaborated. Their modified versions are used as classifiers of aggregates. Within recent years innovative designs of preparation plant machinery and equipment became a very important field of the KOMAG’s activity.

At present in 18 hard coal mines 40 preparation plants are in operation. Among them 33 plants beneficiate steam coal and 7-coking coal. The machines and equipment, used in these processes, include: pulsatory jigs, screens, crushers, heavy-medium separators, Reichert spirals, heavy-medium cyclones, hydrocyclones, flotation machines, vibrating screens and vibrating centrifuges, screen-sedimentation centrifuges, belt presses, filtration presses, pressure filters and disc vacuum filters [6, 11]. At present these technological nodes are automated and visualized.

Several research and development projects, realized at the KOMAG Institute within the recent decade, were oriented onto jigs.

In Fig. 19 OS 18 medium-size grain jig, installed in the modernized Preparation Plant of the Budryk Mine, is shown. The beneficiation node consists of 6 medium-size grain jigs of OS 18 type (70-2 mm), of 2 fines jigs OM 20 type (12-0 mm) (Fig. 20) and of 14 bucket conveyors of B-1000 type (Fig. 21).



Fig. 19. OS 18 medium-size grain jig [KOMAG]

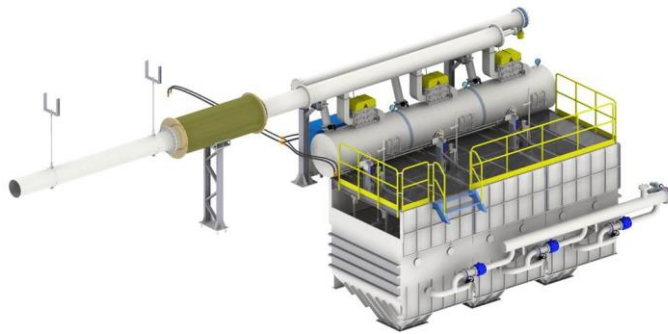

Fig. 20. OM 20 fines jig [KOMAG]

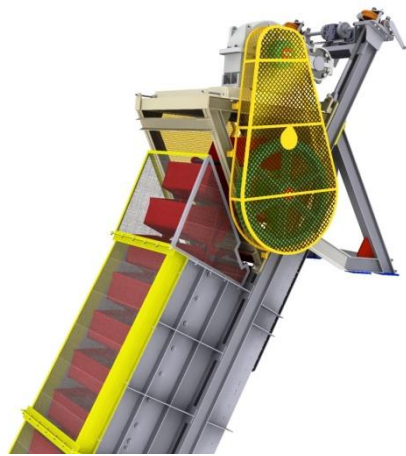

Fig. 21. B-1000 bucket conveyor

The jig node is controlled by the KOGASTER system developed at KOMAG. Due to a modernization of the Budryk Preparation Plant it is possible to beneficiate coal of two types: 34 and 35, using two independent systems.

In the development strategy of the KOMAG Institute of Mining Technology the activities oriented onto an increase of producers' competitiveness due to an implementation of innovative products and technologies play an extremely important role. Market achievements can be measured by a successful operation of mining machines and equipment and significant improvements in the scope of miners' work safety. These activities are realized by KOMAG researchers, designers and specialists working in the accredited laboratories and in the Certifying Body of Products. The KOMAG Institute of Mining Technology is a EU notified body in the scope of three directives: Machinery, ATEX and Safety of Toys.

2. Mine 4.0 in theory and practice

At present Mine 4.0 seems to be a commonly used term although there are some opinion differences among experts, so it was very interesting to find out what Dr. Jacek Korski from the FAMUR Factory intended to say, presenting the paper on Mine 4.0 – in theory and practice. He described characteristic features of industrial revolutions. In the case of Industry 1.0 – it was a steam engine, in the case of Industry 2.0 – use of electric energy, in the case of Industry 3.0 – teleinformation systems, integrated circuits and robots. Industry 4.0 is characterized by a computerization of processes and by autonomous decisions taken by machines. It can be described as the age of a barrier decay between people and machines. It takes advantage of the Internet of People, the Internet of Things, the Internet of Services and the Internet of Data. The key technologies for Industry 4.0 include data storage (sensors), data transmission and communication (RFID), data storage and processing, including data flow, processing in the cloud, group processing in computer networks and also transaction registers of operations instead of a status register, advanced analytics incorporating analyses of Big Data and Artificial Intelligence, as well as a visualization of information using Virtual Reality (VR) and Augmented Reality (AR). As regards the hardware smart robots, drones, wearable devices e.g. smart watches and autonomous vehicles, 3D print in manufacturing processes (AM – Additive Manufacturing) will be used.

The Komatsu/Joy Company has elaborated a map of remote longwall management, which can be treated as a step towards Mine 4.0.

It includes the following components:

- Basic automation of the longwall face containing Faceboss RS20s system, longwall control system and cutting with a memory of cut.
- Monitoring of the longwall operation in the semi-automatic system requiring advanced automation of the shearer, an automation of drives, fast Ethernet network, LASC system of keeping rectilinearity, remote monitoring of the longwall operation and Joy Smarts solutions.
- Remote monitoring in the fully automated system enabling to obtain exact information about the conditions in the longwall face, a visualization of the longwall face, seam management and checking the geometry. Personal proximity sensors and remote management centre are required.
- Remote management in the semi-automatic system requires an advanced control of the armoured face conveyor.

3. Conclusions

- The 20th Jubilee Scientific and Technical Conference KOMTECH-IMTech 2019 enabled an exchange of knowledge as well as scientific and professional experience among representatives of academia, research institutes, producers of mining machinery and end-users from mines.
- After having analyzed a development of mining machinery and equipment over the period of recent seventy years, it can be stated that KOMAG played and still plays the leading role in the process of designing, testing and implementing innovative solutions of these machines.
- A contribution of the KOMAG Institute of Mining Technology to a development of the Polish mining industry in Sovereign Poland was highlighted.
- Some information about Mine 4.0 against the characteristic features of Industry 4.0 was given.
- Bearing in mind a development of mining machinery and equipment, it can be concluded that at present scientists and researchers are oriented on projects reflecting the needs of Mine 4.0.

References

- [1] Centrum Mechanizacji Górnictwa KOMAG. Wydawca: CMG KOMAG, Gliwice 1995.
- [2] Janion A.: Maszyny i urządzenia górnicze. Część II, Wydawnictwo Śląsk, Katowice 1971.

- [3] Jarno L., Orchel S.: Nowoczesne rozwiązania w zakresie przenośników i kombajnów ścianowych. *Maszyny Górnicze* 54/1995.
- [4] Jaros J.: *Historia Górnictwa węglowego w Polsce Ludowej (1945-1970)*. PWN Warszawa-Kraków 1973.
- [5] Kłeczek Z., Kozieł A., Malec M.: 60 lat działań Instytutu Techniki Górniczej KOMAG na rzecz rozwoju przemysłu maszyn górnictwa. *Maszyny Górnicze* 3-4.2010.
- [6] Kowol D., Matusiak P.: Use of a Jig Beneficiation Process for Obtaining Mineral Raw Materials, *Innovative Mining Technologies Conference IMTech 2019, Book Series: IOP Conference Series – Materials, Science and Engineering, Volume: 545, Article Number: UNSP 012006, 2019*.
- [7] Lutyński A., Prostański D.: Rola i znaczenie Instytutu Techniki Górniczej KOMAG w rozwoju górnictwa węgla kamiennego niepodległej Polski. *Monografia KOMTECH 2019. Praca zbiorowa. ISBN 978-83-65593-19-1*.
- [8] Malec M., Kozieł A., Pieczora E.: Innowacyjne rozwiązania maszyn górnictwa opracowane w Instytucie Techniki Górniczej KOMAG, *Górnictwo węglowe Polski i Ukrainy – doświadczenia i współpraca. Konferencja naukowo-techniczna. Maj 2019*.
- [9] Malec M.: *Międzynarodowe Targi Górnictwa, Energetyki i Metalurgii SIMMEX'95. Maszyny Górnicze* 54/1995.
- [10] Matusiak P., Kowol D.: *Maszyny do przeróbki mechanicznej konstruowane w ITG KOMAG. Maszyny Górnicze* 2/2013.
- [11] Matusiak P., Kowol D.: State-of-the-Art Pulsating Jigs of KOMAG Type, *Scientific and Technical Conference on Innovative Mining Technologies IMTech 2019, IOP Conference Series – Materials, Science and Engineering, Volume: 545, Article Number: UNSP 012008, 2019*.
- [12] Meder A., Mazurkiewicz T.: Innovative machines in the conditions of sustainable development. *Gospodarka Surowcami Mineralnymi – Mineral Resources Management, Volume 24, Issue 4, Pages 75-86, 2008*.
- [13] Meder A., Mazurkiewicz T., Malec M.: Achievements of the KOMAG Mining Mechanization Center in technical restructuring of the Polish coal mining industry, *1st American-Polish Symposium on Mining in the New Millennium, Mining in the New Millennium – Challenges and Opportunities, Pages 213-221, 2000*.
- [14] *Stan przeróbki mechanicznej węgla kamiennego w Polsce. Opracowanie Państwowej Agencji Restrukturyzacji Górnictwa Węgla Kamiennego S.A. Katowice, maj 1997*.
- [15] Strzeмиński J.: 30 lat produkcji nowoczesnych ścianowych obudów zmechanizowanych w Polsce – część I. *Mechanizacja i Automatyzacja Górnictwa. Nr 6/401/2004*.
- [16] Wiland J.: *Album Maszyn Górniczych. Wydawnictwa Techniczne ZKMPW 3971/58*.